

APPLY LUBRICANT TO ALL SEALS  
PRIOR TO INSTALLATION.  
DO NOT USE SILICONE TYPE LUBRICANTS.  
FOR PROPER ARM MOUNTING SEE IS1505.

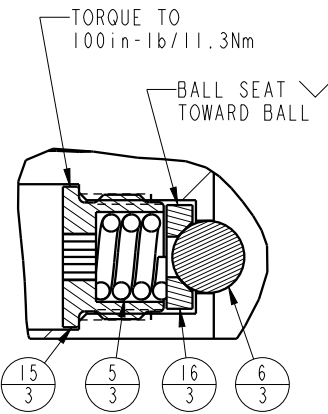

DETAIL A  
SCALE 1.500

No.	QTY	PART No.	DESCRIPTION	Std Seal Kit	FKM Seal Kit
N/A	N/A	IS1505	INSTRUCTION SHEET, ARM INSTALLATION		
N/A	N/A	6V711044	SEAL KIT, FKM		
N/A	N/A	60711044	SEAL KIT, STANDARD		
20	1	39V11051	WIPER, PRESS-IN, (1-1/2)	X	X
19	1	39H51002	O-RING, (-033)	X	39V51002
18	1	81592127	CAM, SC, LP, 7500/33KN, LH, LS, TC		
17	1	81542102	BASE, SC, BF, LP, 33KN		
16	3	81532108	SEAT, BALL, SC, LP, TC		
15	3	81532107	RETAINER, SC, LP, TC		
14	1	81512112	PLUNGER, SC, LP, 7500/33KN, DA, LS, TC		
13	2	43068006	PLUG, 1/4 BSPP MALE		
12	1	39054017	BU RING, (-033)	X	39054023
11	1	39054016	BU RING, (1.5x.125x.063)	X	X
10	1	39052030	SEAL, CROWN, 1-3/4x2-1/8x1/4	X	39V52030
9	2	39051041	O-RING, (-006)	X	39V51041
8	2	39050042	O-RING, (-011)	X	39051025
7	1	39011075	SEAL, LL, (1-1/2 X 1/8 X 1/8 1-3/4)	X	39V11075
6	3	23650004	BALL, TUNGSTEN-CARBIDE .250		
5	3	23350066	SPRING, COMPRESSION		
4	10	21500305	SHCS, M8 X 1.25-66 X 30MM		
3	2	21500200	WASHER		
2	3	21500031	SHCS, M5 X 0.8 X 14, ALY		
1	2	21500019	SCREW, CAP, BTNH, M3 X 6, ALY		

<h3>PARTS LIST</h3>	<p>VEKTEK, INC. 1334 E. SIXTH AVE. P.O. BOX 625 EMPORIA, KS. 66801 U.S.A.</p>
PARTS LIST, ASSY, SC, LP, TC, BF, 33KN, DA, LH, LS	SIZE A <b>MPLV7259</b>
REV B	SHEET 1 OF 1

B	5762	RELEASE	JDW	07/18/25
REV	IN ACCORDANCE WITH ECN	EFFECTIVE DATE	REVISED BY	DATE
DRW BY:	JDW	DRAWING STATUS: <b>Released</b>		
DATE:	03/04/19	PRODUCTION APPROVED FOR RELEASED STATUS ONLY		

